

**mott** *corporation*

84 Spring Lane, Farmington, CT 06032-3159  
860-747-6333 Fax 860-747-6739  
www.mottcorp.com

**MOTT POROUS METAL MEDIA FOR POLYMER  
MELT SPIN PACK FILTRATION**

I. Lewis Langley  
Dr. Kefah Khalaf  
Mott Corporation

Presented at the  
2nd International Polymer Filtration Conference

Singapore

May 19-20, 1998

# MOTT POROUS METAL MEDIA FOR POLYMER MELT SPIN PACK FILTRATION

## Introduction

The media used for polymer filtration immediately prior to the spinnerette is specific to every fiber producer's process. Within a single organization there is no consensus of opinion as to which media provides optimal results; opinions are usually strong and based on historical data and time honored usage. Setting up a production run to evaluate the efficacy and efficiency of filtration performance has been difficult due to the perpetually changing production schedules.

Filtration processes fall into three categories: cake filtration, depth filtration and surface filtration.

**SURFACE FILTRATION:** Particles larger than the pore size are retained on the upstream surface of the filter.

**DEPTH FILTRATION:** A depth-type filter usually consists of a graded structure providing an increasing chance of finer particles being trapped on their passage through the filter media.

**CAKE FILTRATION:** Removes bulk solids from a stream by producing a layer of discrete particles on the surface of a filter that forms a cake. The loose bed construction of the cake forms an additional level of depth filtration.

This paper discusses depth filtration with one significant exception. The media used in polymer filtration creates a situation in which the major portion of the fluid stream is channeled in one direction and smaller portions are channeled in other directions. The successful application of this selectivity is the essence of filter engineering and the means of separating particulate matter from the fluid.

The presence of contaminants in polymer melts can affect the quality of the final product. These contaminants are normally present in different sizes and their effect is dependent on their quantities which may cause fiber breakage.

These contaminants may be divided into two groups:

- Solid particles from polymer raw materials, corrosion of pipelines, etc.
- Gel particles of similar composition as the polymer which is formed due to cross-linkage of polymers.

Gel particles can be classified as:

- Non-deformable gels (hard gels). This type of gel does not change size or form.
- Deformable gels (soft gels). This type of gel does change in size and form when approaching porous media.

The primary function the media must accomplish is the retention of particulate matter. To do this we must decide how to best achieve the selective flow. This is done by selecting the proper media that can provide a means of separating the particulate matter while minimizing residence time to avoid creating adverse effects such as the formation of gels and carbonization.

Second, the media must perform a degree of shear as an integral part of its fluid flow properties. Shear is described as the process of molecular alignment in which the lateral bonds between long chain molecules are subjected to greater force than the longitudinal chain bonds. This is accomplished by creating a fluid velocity profile through the small orifices forcing the center of this stream to a higher velocity than the side stream thereby fracturing the side chains.

It is also analogous to aligning the proverbial bundle of sticks to achieve greater strength by their parallel alignment. This function is no less important than the separation of the particulate matter and should, in fact, be considered an integral part of introduction of the polymer to the spinnerette capillary.

Figure 1 shows the classical production system for the manufacture of melt spun fibers.

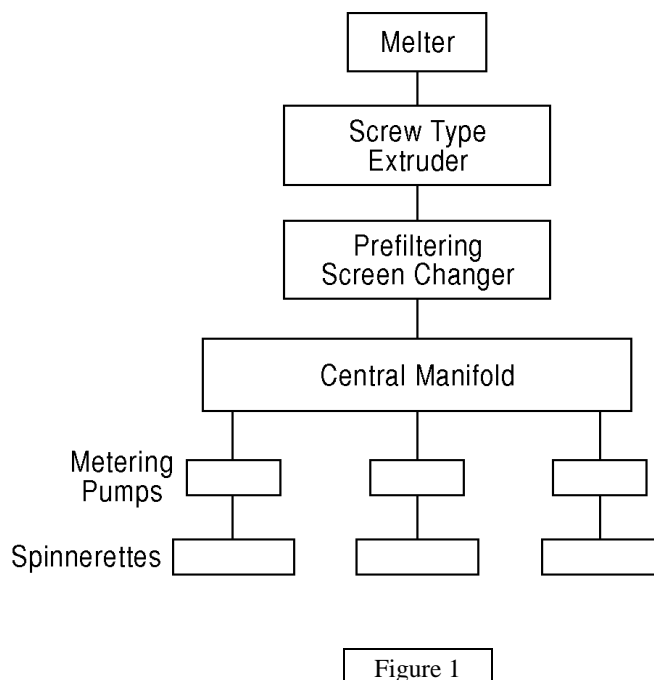

A typical spinnerette pack assembly consists of the inlet head, the pack body and a spinnerette holder (see Figure 2).

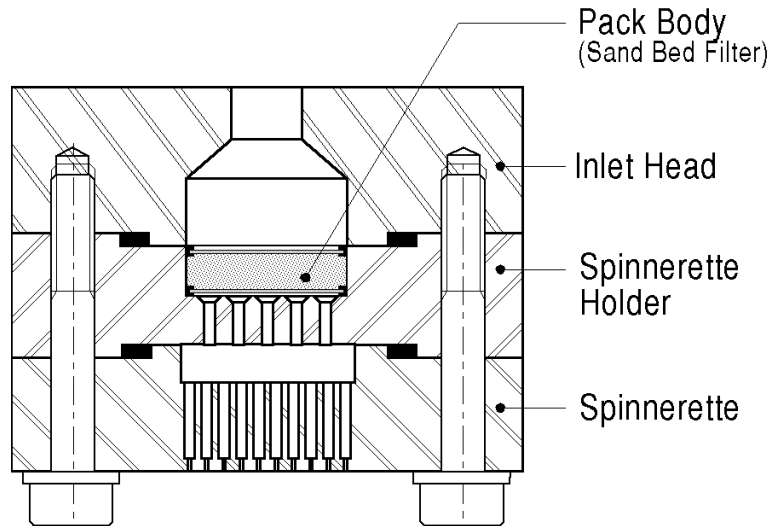

Three types of pack filtration systems are currently used: sand bed filters, wire mesh filters and porous metal filters.

### 1. SAND BED FILTERS:

This filter consists of discrete layers of very carefully graded sand particles supported by wire mesh upstream and downstream. The principal disadvantage of the sand filter is the tendency for the molten polymer to channel, thus bypassing the filter.

Sand remains the traditional standard of the industry and is usually the media by which all other media are measured. It can be graded into sizes from large, coarse grains to an infinitely small grain, hardly larger than a single silica crystal. Several companies will deliver a close fractionation of sand in any grade desired at a very economical price. They can also provide sand in various degrees of cleanliness and hardness. Inexpensive and easy to obtain, sand is not a candidate for reuse but may eventually become a problem of disposal. It is relatively easy to contain in a cavity, using the proper screen wire mesh or porous metal with adequate seals and retainers.

One problem with sand is that regardless of the care used in introducing the polymer to the sand, some degree of surface disturbance invariably occurs. Even in the best of circumstances, some degree of channeling occurs due to varying flow properties during the life of the pack. Studies performed in the late 50's indicated that it took approximately six hours of steady flow at a rate of 85 lbs/hr to completely saturate a sand bed 5 inches in diameter.

**GRADES OF SAND:**



80-80 Sieve (240X)

80-100 Sieve (240X)

120-160 Sieve (240X)

Sand is an excellent media for tailoring a progressive filter. Discrete layers of carefully graded sand, properly supported and having a means of distributing polymer uniformly across the top layer can selectively separate the filtration process from the shear action required without compromising the efficiency of either function. Being a loose media that can move vertically as well as horizontally, the sand bed provides infinite side channels for particulate retention. The textured grain surface provides a large area on which the polymer molecules are secured with multiple points of attachment involving entire chain segments of the molecule. The low probability of a simultaneous release of all points of attachment supports the explanation of the shearing action that takes place in the voids (pore) between adjoining crystals. With all of the side channel capacity and a loose aggregate that allows internal expansion, one would expect sand to have an infinite packlife.

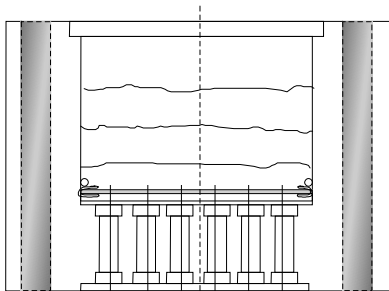
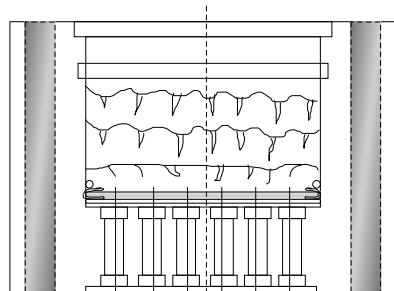

Fig 1A - Unused 3 Layers Sand Pack  
Fig 1B - Initial Channeling After  
Typical for Nylon 6 Extrusion



35 Hours Use at 25-30 lbs/hr

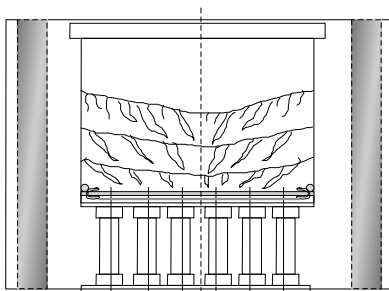
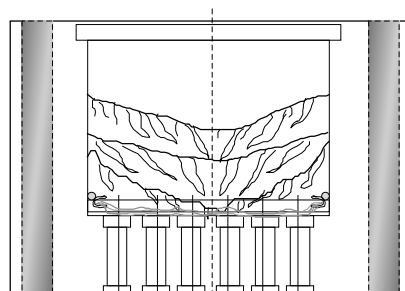

Fig 1C - Progressive Channeling  
Fig 1D - After 50-60 Hours  
After 40-50 Hours



The industry-at-large accepts sand as a basic media for Nylon 6 and 66. However, the industry is generally split on the use of sand in filtration of polyester and no one employs sand for polypropylene filtration. This diversity of opinion is based on the type and degree of filtration required for these polymers, however, sand is chemically compatible with all polymer systems.

In an effective sand bed, the pressure drop is relatively high when compared with other media. This is due not only to the tortuosity of the path through the sand bed, but a compaction of the sand due to the interface boundary layer formed between grades of sand. When using distinct layers of sand, the grains of one layer mix at the interface with grains of adjacent layers, creating an intermediate layer of mixed particles that exhibit a higher flow restriction than either layer. During the first four to six hours, a boundary layer of particulate matter and small grains of sand form within the upper 10% of the bed thickness. This causes excessive compaction and later contributes to the relatively short life of this media.

## 2. MULTIPLE LAYERS OF WIRE MESH:

This filter avoided the channeling problem associated with the sand bed filter, however, it fails to remove the gels. Furthermore, the number of layers required for adequate filtration and shear raised the cost of the pack filter to a prohibitive level.

Screen wire cloth is a woven cloth of very finely drawn stainless steel wires. The mesh designation is the number of openings per linear inch, where the first figure is the longitudinal measurement (or warp yarn) and the second is the width (or shute yarn). Mesh count and the diameter of the wire used complete the general specifications for wire cloth but variations in material, weave employed and calendaring can be included to achieve different filtration requirements.

The specification for a filter using wire cloth is much more detailed. Federal Specification RR-W-360 is the standard for manufacturing the cloth and wire used. Rim binder material and dimensional tolerances (including flatness) are specified in detail. Arrangement of the respective layers should be shown on the drawing and detailed verbally to preclude one layer blinding or shading the pores of the lower layer. The example to the right shows a sample of twill weave material. Long narrow openings of space between the wires and raised shute yarn gives the Dutch weave or Twill weave a low micron retention rating and good resistance to face blinding.

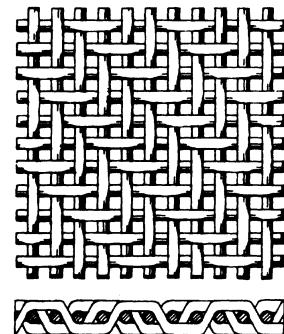

Cleanliness and good workmanship specifications are standard for all quality manufacturers and should not be relinquished, regardless of the price of the screens. An inspection acceptance clause should be included to assist Purchasing in enforcing the quality requirements the product demands.

To use screen wire cloth effectively, it must be supported by a screen of sufficient strength to bridge the openings. In the direction of polymer flow from top to bottom, the upper layer should not present greater than 3 unsupported wires to the lower layer. The bottom layer

in the pack must span the holes of the Breaker Plate in a similar manner. By placing successive layers at a slight angle to each other, additional support is achieved and shading is avoided. Above the barrier screens a protective layer of larger mesh screen prevents large particles from blinding the surface or rupturing the fine screen.

### 3. SINTERED POROUS METAL FILTERS

Two types of sintered porous metal filters were developed by Mott Corporation: discs, and the Extended Area Pack (EAP). Extended Area Packs increased the filtration area within the pack body by factors ranging between 3 and 7 and reduced the residence time of the polymer in the pack.

#### **MOTT EXTENDED AREA PACK FILTER**

The extended area pack filter is comprised of a base plate which is incorporated into a closed-packed array of closed-end tubular filter elements as shown in Figure 3.

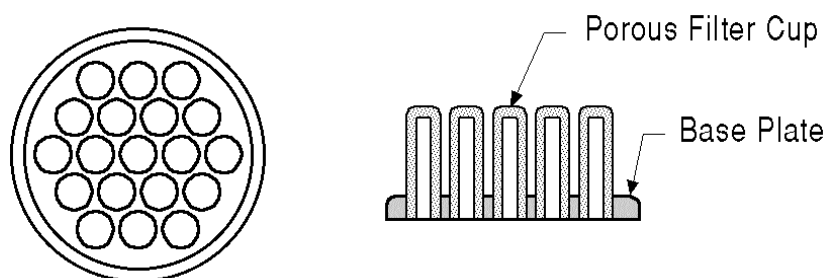

Typical Extended Area Filter Pack

Figure 3

Tests on the closely-packed tubular element extended area filters have indicated resistance to collapse pressures at melt spinning pressures in excess of 7,000 psi when the structures have been fabricated from 316L stainless steel. When fabricated of higher strength alloys, the extended area filters have been shown to be resistant to pressures up to 20,000 psi.

For this discussion the alloy and the powder source will be restricted to 316L stainless steel. Control of the alloy and atomizing process is critical to the sintering properties and is closely controlled by chemical analysis at every point. The powder is preferably a rounded edge particle providing surface areas that can become sintered to other particles.

As described, the raw powder produced is a random mix of fine and large particles. This is graded by a series of sieves to provide the precise fractions that can later be mixed in the proper relationship to produce specific properties such as pore size, density, pore geometry, etc. The powder is thoroughly mixed and dry compacted into a mold to make a "green" part which can be easily handled and inspected. The green part is then placed on a ceramic tray and put into a high temperature oven where the sintering takes place in a reducing atmosphere of hydrogen or dissociated ammonia.

Precise sintering temperature controls and the time cycles at certain temperature levels (predetermined by the powder fractions used) produce a porous sintered metal. In this reducing atmosphere, no oxides interfere with the sintering process and the particle bonding is 100% complete.

Pore size distribution is controlled primarily by the powder particle size distribution (percentage of each sieve series included in the mix) and also by the density provided in compacting this powder into the mold. The finer the powder, the finer the pore size of the finished product. However, without proper compaction, the sintered piece lacks mechanical strength and ductility. Properly pressed and formed, sintered powdered metal has no media migration and has been approved for food and medical uses.

Other processes for manufacturing porous sintered metal utilize organic binders, nitrogen atmosphere or vacuum furnaces for ease of manufacturing and cost reduction. These products have their applications, they have reduced strength and are susceptible to media migration. They also utilize a general mix of powder in a standard bell shape curve of particle size distribution that does not give uniform pore size or pore definition of a sieved selection process.

Porous metal filters are a true static filter that have both depth and tortuosity. The irregular shaped surface pore provides a relatively large filtration surface area but is rated by its low micron sized openings. As this pore continues through the mass, the fluid stream encounters sharp intersections that split the stream and allow side streams to be channeled into ever decreasing side channels and dead spaces.

You can see in Figure 4 the pore shape varies continuously in cross-section shape and size. This feature is unique to porous sintered metal in that all of the particles of metal are permanently attached to each other and the voids between particles act as static pores. Residence time is less than that of an equivalent thickness of screen wire cloth or felt metal and particle retention is positively determined by the pore shape. The porous sintered metal surface blinding rate is higher than screen or sand but less than felt metal and on par with perforated metal.

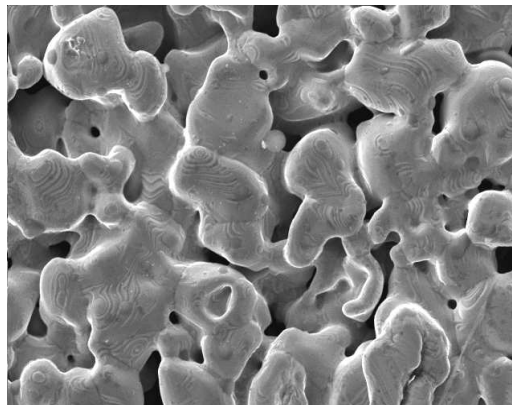

Figure 4



With its rough surfaces and irregular particles, sintered porous metal presents a large wetted area to the polymer flow resulting in greater interfacial tension to the side stream than any other media with the exception of loose shattered metal. Theoretically, the shear rate can be tailored to give any desired degree of shear consistent with acceptable pressure drop and blinding rate.

Using porous metal as a combination filter, providing both high shear and efficient filtration, is not recommended. Both features can be tailored to specific values making it more practical to use an Extended Area filter and a thin shear disc.

In addition, sintered porous metal can be formed in shapes that give greater surface to a filter bed. These structures are called Extended Area Packs. They are an extension of the normal area presented to the polymer flow path made by incorporating a close-packed array of closed-end tubular filter elements in a base plate. Monolithic structures have also been used but their irregular density and variable wall thicknesses sacrifice usable filtration area making their use impractical. The tubular elements have the greatest resistance to crushing of any shape used and regularly withstand pressures in excess of 5000 psi.

Figure 5 shows a typical pack make-up which employs a Mott Expandable Seal. These seals have proven highly effective in eliminating not only leaks around the filter, but also in eliminating pack leaks between the adjacent pack parts and the junction between the pack body and the spin block.

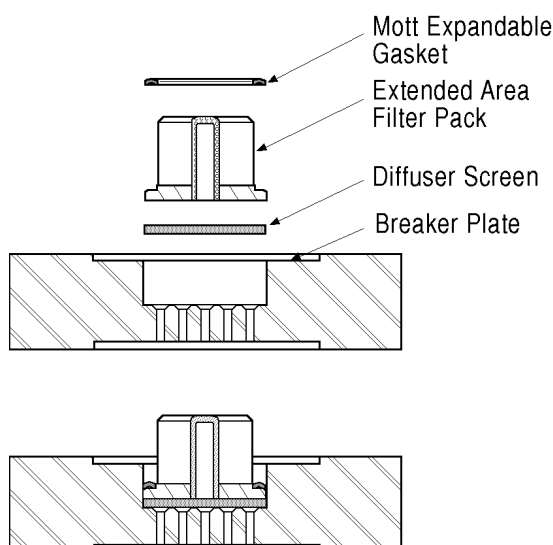

Figure 5

The diffuser screen shown in Figure 5 between the base plate of the Extended Area Pack filter and the breaker plate serves the function of compensating for misalignment between the breaker plate hole pattern and the outlet port pattern of the extended area filter. The polymer effluent from the Extended Area Pack filter flows laterally between the wires of the diffuser screen and exits through the breaker plate to the spinnerette port.

The combination of an Extended Area Pack filter and a separate shear element positioned downstream of the filter, immediately adjacent to the upstream face of the spinnerette would enable the polymer spinners to separate the filtration function in the pack. The shear disc

performance can be varied without impacting the Extended Area Pack filtration characteristics (Figure 6).

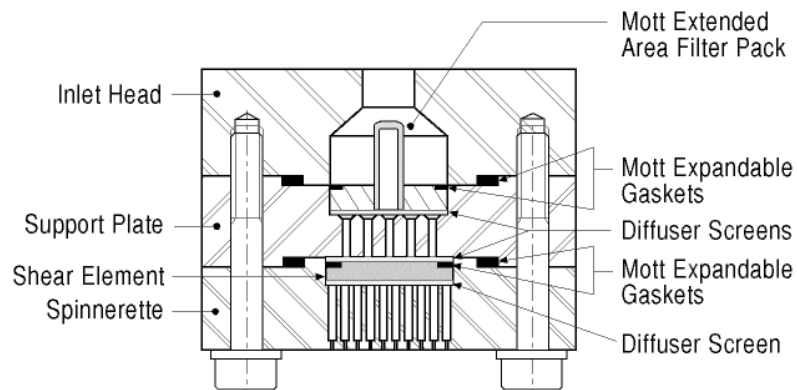

Figure 6

### **SHEAR IN THE EXTENDED AREA PACK SYSTEM**

The pack filter system removes any unwanted debris from the polymer stream just before it enters the spinnerette and will shear the gels so that the extruded strands will not fracture when stretched in the drawing operation. The pack filter performs both the shear and filtration function which results in using finer filtration than actually required, leading to reduced pack life.

The advent of the Extended Area Pack filter, by virtue of its significant area increase, yielded the extended life but drastically reduced the effective shear by reducing the flow velocity through the filter medium at a given pack throughput. The object of the shear is to break the lateral bonds between adjacent chains of the polymer without breaking the longitudinal intermolecular bonds, which would result in shortening of the molecular chains or degradation of the chain molecular weight.

The lateral bond fracture is induced by forcing the polymer to increase its velocity through a series of constructions such as the pores of Mott powder metal media. The powder particles are irregular in shape which increases its effectiveness on shearing its polymer chain. By extruding the polymer through a porous metal matrix with a very large specific surface, we create velocity profiles within the pores. By doing so, we are causing the adjacent stream lines within each velocity profile to be moving at different rates with respect to one another thereby fracturing the lateral chain bonds. However, after passing through the shear medium, if the polymer is allowed to reduce its velocity, there is a tendency for the lateral chain bonds to reform.

The Extended Area Pack filter development has resulted in dramatic increases in pack on-stream life, and in many instances, has enabled the synthetic fiber producer to employ a finer degree of filtration than had previously been possible in the pack system due to high start-up pressures and extremely short pack life.

Due to a significant reduction of filter area, the velocity of the polymer within the pore must be greater than the velocity through the filter medium. The degree of shear is governed by the pore size and pore volume existing in the shear element for successful operation of the system. The only limitation of the shear element is that its degree of filtration must be coarser than that of the Extended Area Pack filter. The sole function of the shear element is to locally increase the unit area flow velocity and not to serve as a secondary filter.

With a 4-7 fold increase in area available, the Extended Area Pack enables the fiber producer to use a finer degree of filtration for the same pressure drop than had previously been possible. It is no longer necessary to push a pack to the higher pressures that require elaborate sealing, and shear can be treated as a separate function.



Extended Area Pack

Although the Extended Area Pack filter in combination with the shear element is initially more expensive than the conventional sand and screen filter, field experience has shown that the Extended Area Pack filter can be cleaned and reused as many as 20 times. The reuse life depends upon the effectiveness of cleaning operations employed and assume reasonable care in handling the filters to avoid mechanical damage. Cleaning techniques include open furnace cleaning, solvent baths or salt baths followed by ultrasonics.

The advantages of the Mott Extended Area Pack filter can be summarized as follows:

1. Extension of on-stream life of the filter.
2. Fine filtration with no increase or decrease in pack start-up pressure.
3. Product improvement by independent shear control.
4. Higher reproducibility of filtration and shear control.
5. Cleanable and reusable.